

You Can Rely On Horizon Rollers For High Performance

ALUMINIUM ROLLERS

TROUGH, VEE & FLAT RETURN ROLLERS

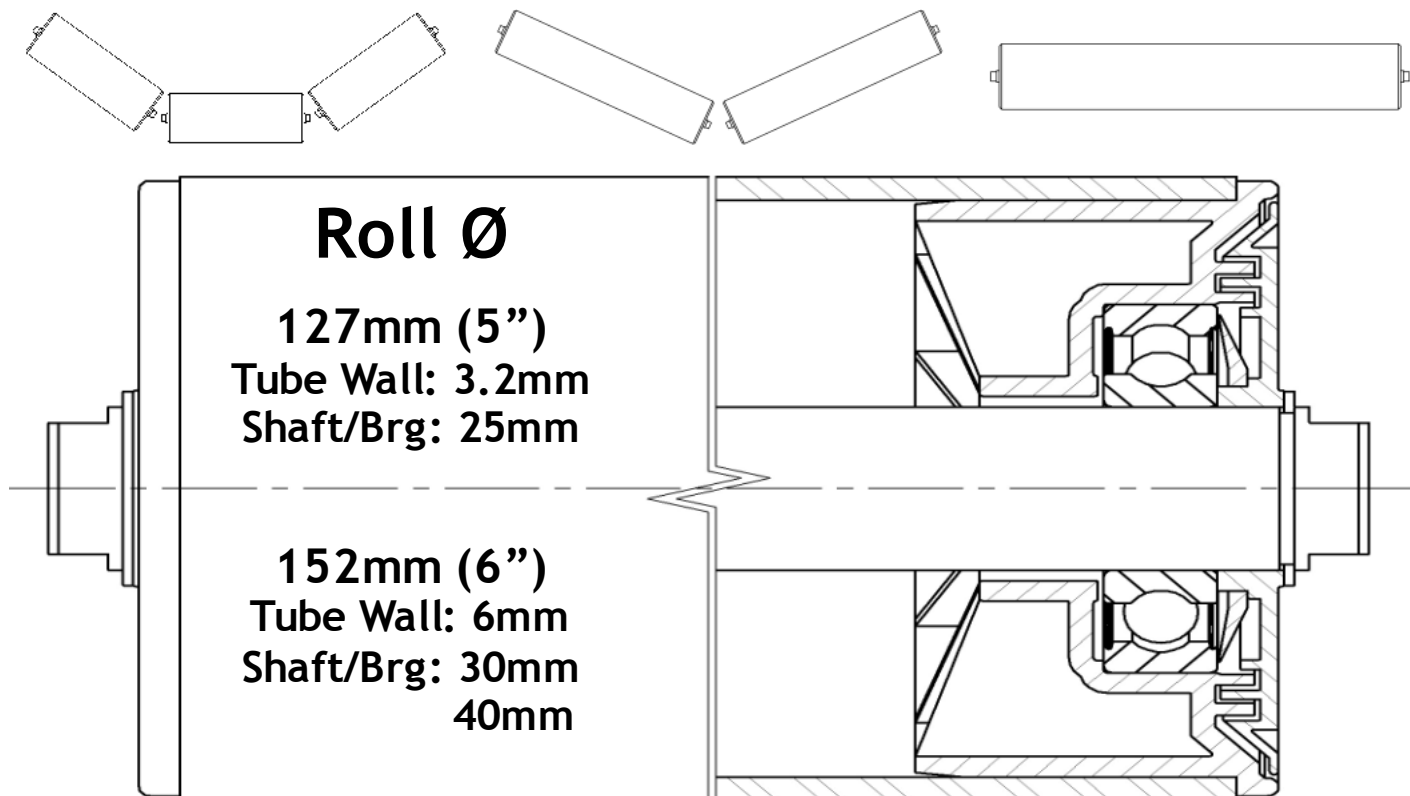

The Aluminium roller has been designed to be very strong & lightweight. The bearing housings are constructed from glass reinforced nylon and also incorporates a moulded-in copper electrostatic discharge wire which connects the roller shell to the bearing.

Fitting heavy steel return rollers can be a huge health & safety problem, which could cause unnecessary injuries to site personnel.

All rollers are fitted with steel shafts and sealed greased for life bearings.

Seals are multi labyrinth c/w bearing lip seal

Benefits

- **Lightweight**
- **Strong**
- **Non Magnetic**
(For use under magnets)
- **Reduced Noise**

HORIZON[®]

Hayseech Road, Halesowen, West Midlands B63 3PD.

Tel. +44 (0)121 550 2218 Fax. +44 (0)121 550 2243 Email: info@horizonconveyors.co.uk

Find out more about the Horizon range at: www.horizonconveyors.co.uk

You Can Rely On Horizon Rollers For High Performance

QUALITY IDLER ROLLERS

ROLLERS DESIGNED FOR SPECIFIC APPLICATIONS

The table below shows the difference in weight between Steel Return Rollers, Plastic and Aluminium Return Rollers for handling and fitting purposes.

All roller comparisons are based on heavy duty Ø30,35 & 40mm shaft & bearings.

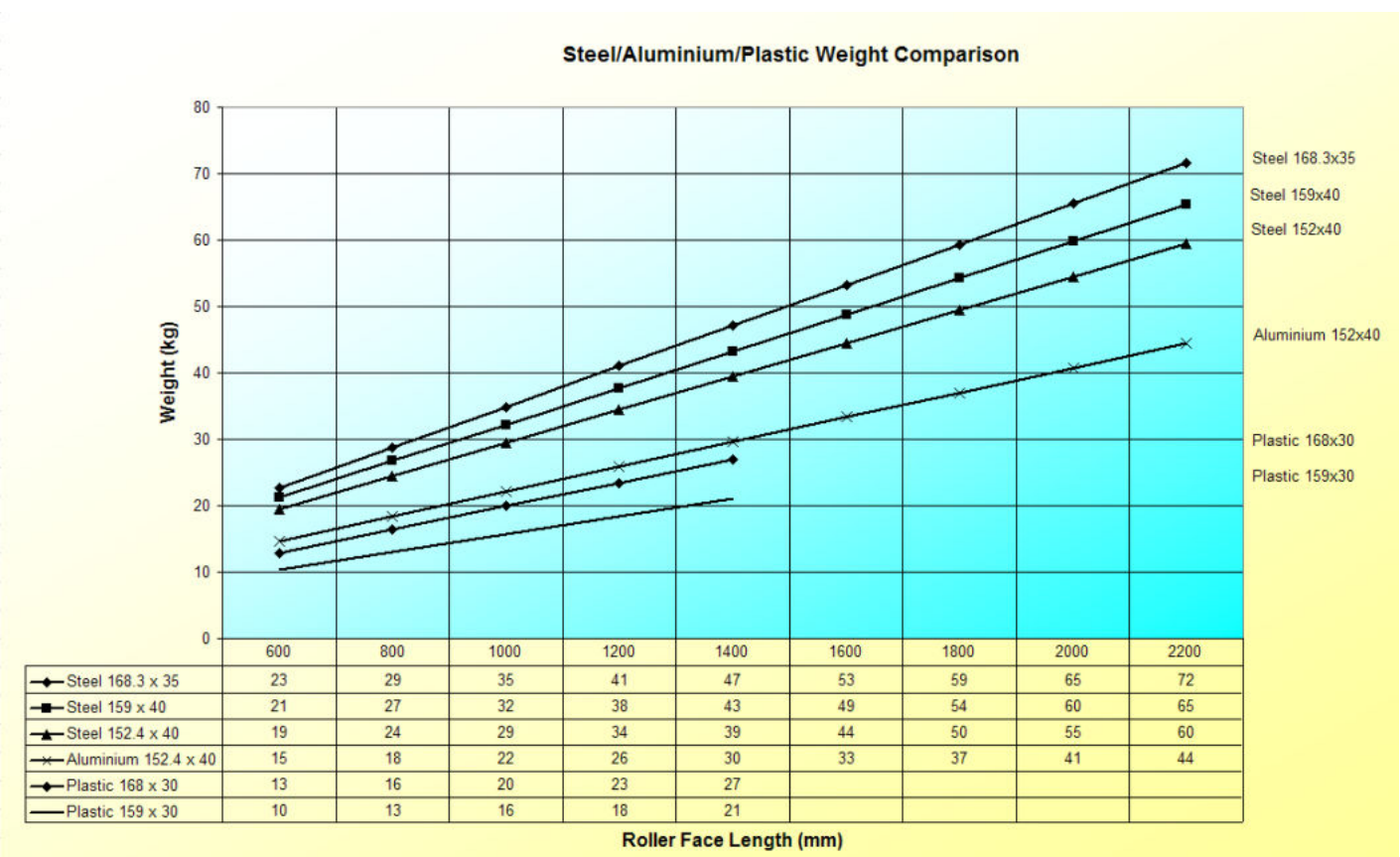

Note: Figures are estimates only

Horizon's Lightweight Aluminium Rollers address the Health and Safety risks associated with fitting long heavy steel return rollers



Hayseech Road, Halesowen, West Midlands B63 3PD.

Tel. +44 (0)121 550 2218 Fax. +44 (0)121 550 2243 Email: info@horizonconveyors.co.uk

Find out more about the Horizon range at: www.horizonconveyors.co.uk