

CONVEYOR EQUIPMENT

SECONDARY BRUSH CLEANERS

Heavy Duty Brush External Motor (Spring Tensioned)

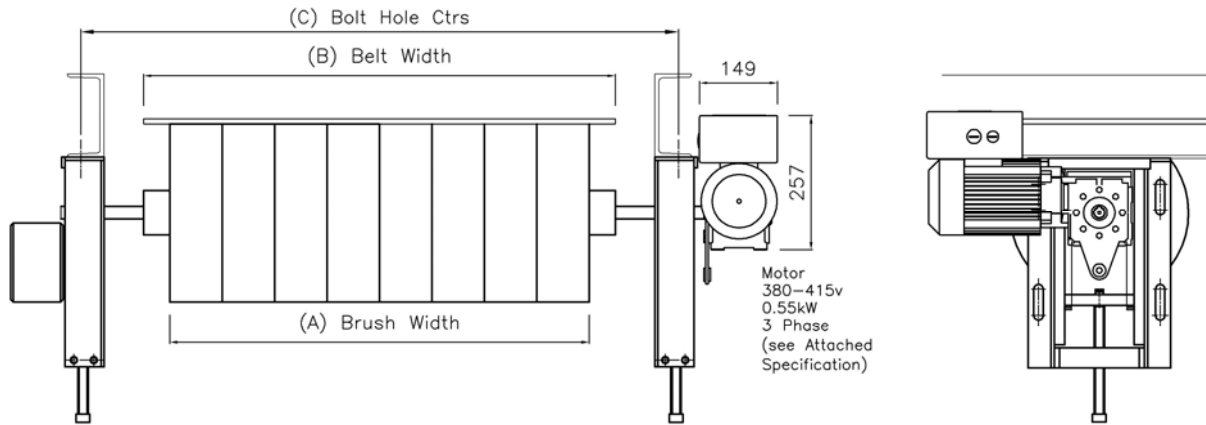

RTS Brush Integral Motor (Rotary Tensioned)

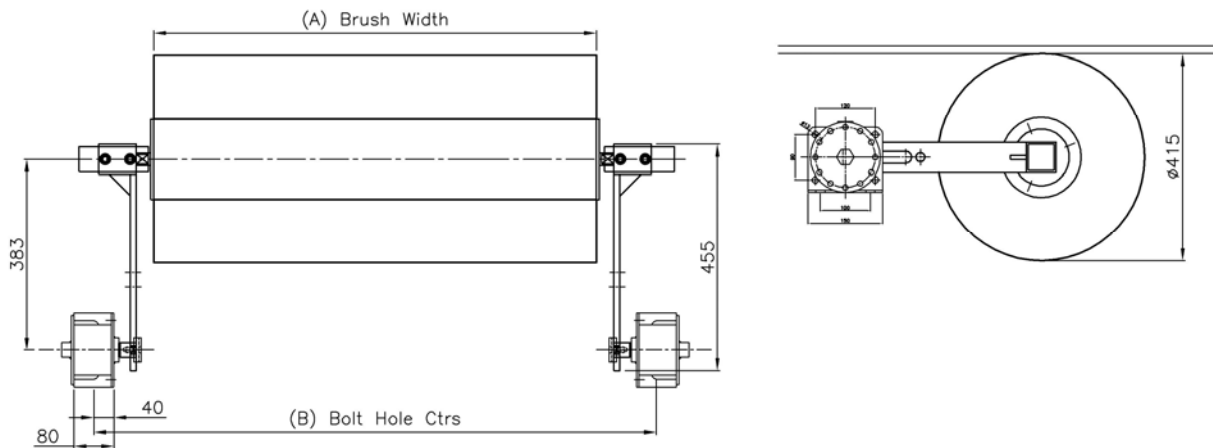

RTS Static Brush (Rotary Tensioned)

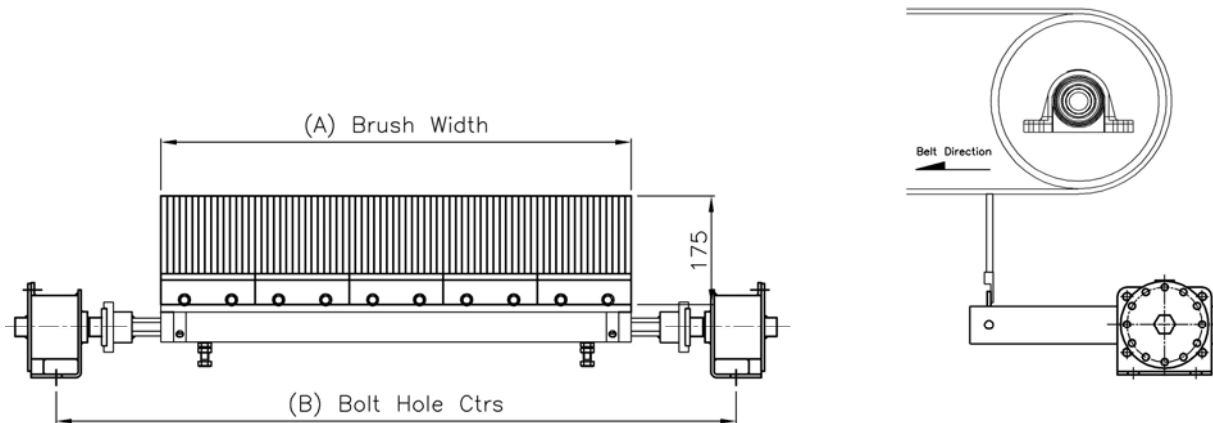

Note: Should you require any further technical advice with regards to drawings, fitting and maintenance please contact us

Find out more about the Horizon range at: www.beltscrapers.co.uk